

**Equipment and Operation of New Ultra-High Speed
Continuous Annealing Line for Tin Mill Black Plates**

要旨

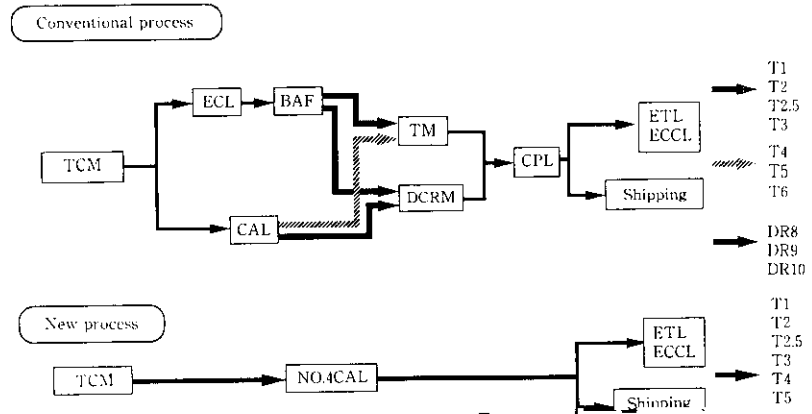
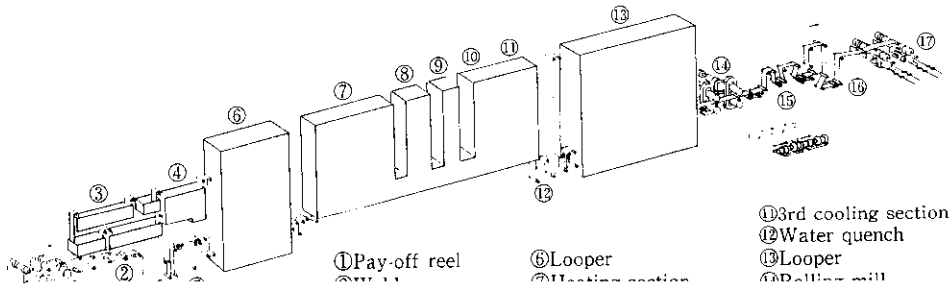
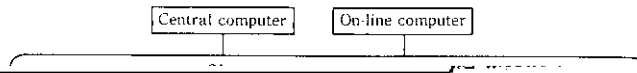

Fig. 1 Comparison of conven-



[The page contains several lines of text that are almost entirely obscured by heavy black redaction bars. Only a few fragments of text are visible, including the word "WILL" on the left margin and some faint characters in the center of the page.]





らテンションリールへの搬送設備を設置した。これにより、スリーブはトラックから連続的に受入れられた後、内径、長さおよび真円

