Construction and Operation of Dry Type Dust-Removal Equipment for Blast Furnace

(Kunihiro Tanaka) (Toshiyuki Matsumoto) (Teruo
Kanatsuna) (Katsunori Yoshida) (Hideyuki Kamano)
(Yunosuke Maki)

:

1986

4.5kWh/t 11

Synopsis :

Dry type dust-removal equipment was installed at Chiba No.6 blast furnace in September 1986, and has been smoothly operating since the start of its operation. The dust-removal equipment uses a bag filter, which is under stable, continuous operation through the use of a unique and highly accurate temperature control system of water splaying. As a result of installing the dry type dust-removal equipment, generating electrical power by the top pressure recovery turbine increased by 4.5kWh/t (about 11%) and the running cost of the BF gas heater and others have been reduced.

(c)JFE Steel Corporation, 2003

Construction and Operation of Dry Type Dust-Removal
Equipment for Blast Furnace

要旨





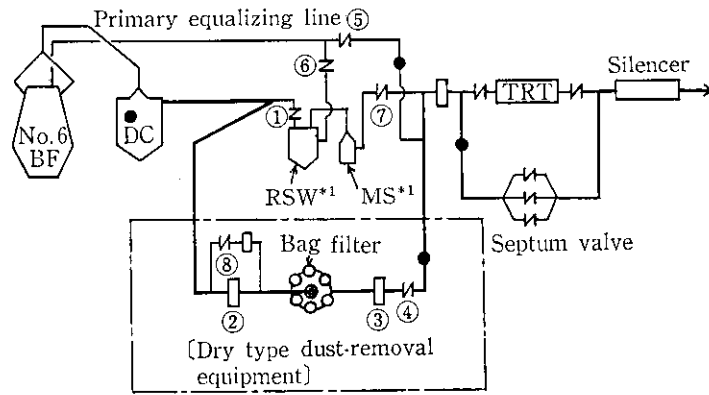

- | | |
|---|--|
| ① RSW inlet butterfly valve | ⑥ RSW outlet butterfly valve for primary equalizing line |
| ② Bag filter inlet goggle valve | ⑦ RSW outlet butterfly valve |
| ③ Bag filter outlet goggle valve | ⑧ Filling pressure butterfly valve |
| ④ Bag filter outlet butterfly valve | ● Installing position of gas cooling device |
| ⑤ Bag filter outlet butterfly valve for primary equalizing line | *1 Wet type dust-removal equipment |

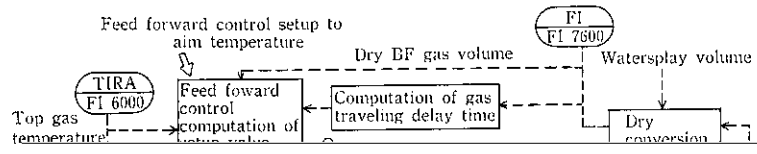

Table 2 Example of separated dust component

